

가  
 1990  
 가  
 가  
 가

“  
 21  
 가  
 가  
 10,000 2,400  
 21



. IMF

IT  
 Up-grade  
 O/A

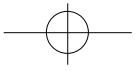

가

2000

가

Back-up

, PC

7

가

가

가

가

盛年不重來 一日難再晨 及時當  
勉勵 歲月不待人

“

”



R e n o v a t i

# 리노베이션 수요전망

# 시장현황과

IMF , 가

50%

, IMF 가

70

가가

가

가 2000

- 1 :
- 2 :
- 3 :
- 4 :
- 5 :

가

(Renovation)  
(Life Cycle)

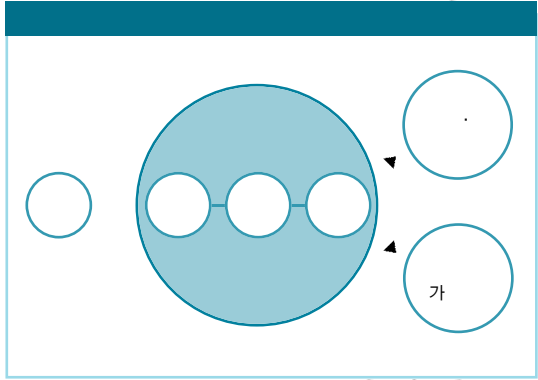

(Remodeling, 改修),  
 改裝), (Recycling, 再活用),  
 (Restoration, 復舊)

(Retrofit,

(Renovation)

가



가

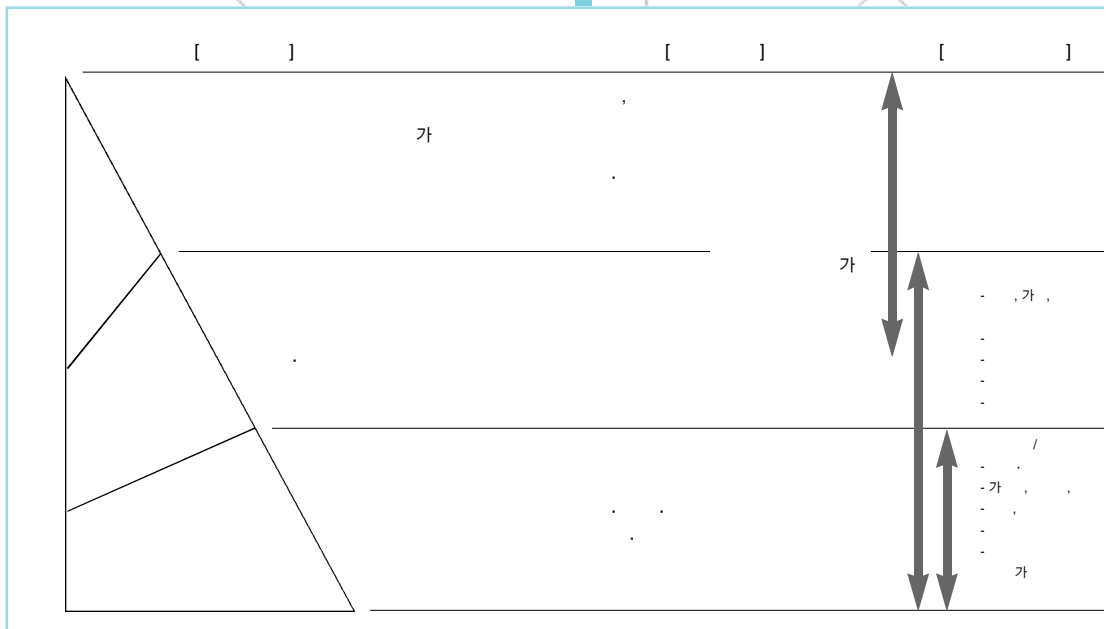

# R e n o v a t i o n

(單一職人) 가  
 가 가  
 / , , / , ,  
 30 50%

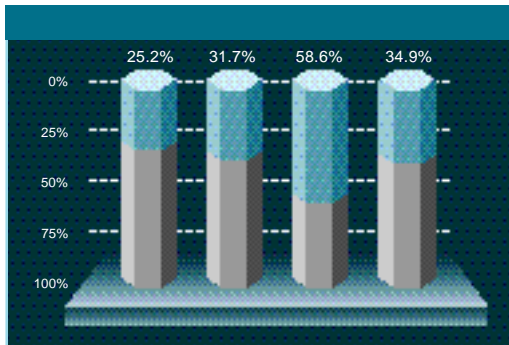

90  
 , /  
 (95 )  
 25.5%

1995  
 1) , 2010  
 가  
 1990  
 가 , (98 )  
 31.7% <sup>2)</sup>,  
 58.6% <sup>3)</sup>  
 , 1990  
 (The 1990s - The  
 Renovation Decade)  
 10

가  
 ,  
 가  
 , (97 )  
 34.9%  
 2000  
 2.2%

가  
 ,  
 가

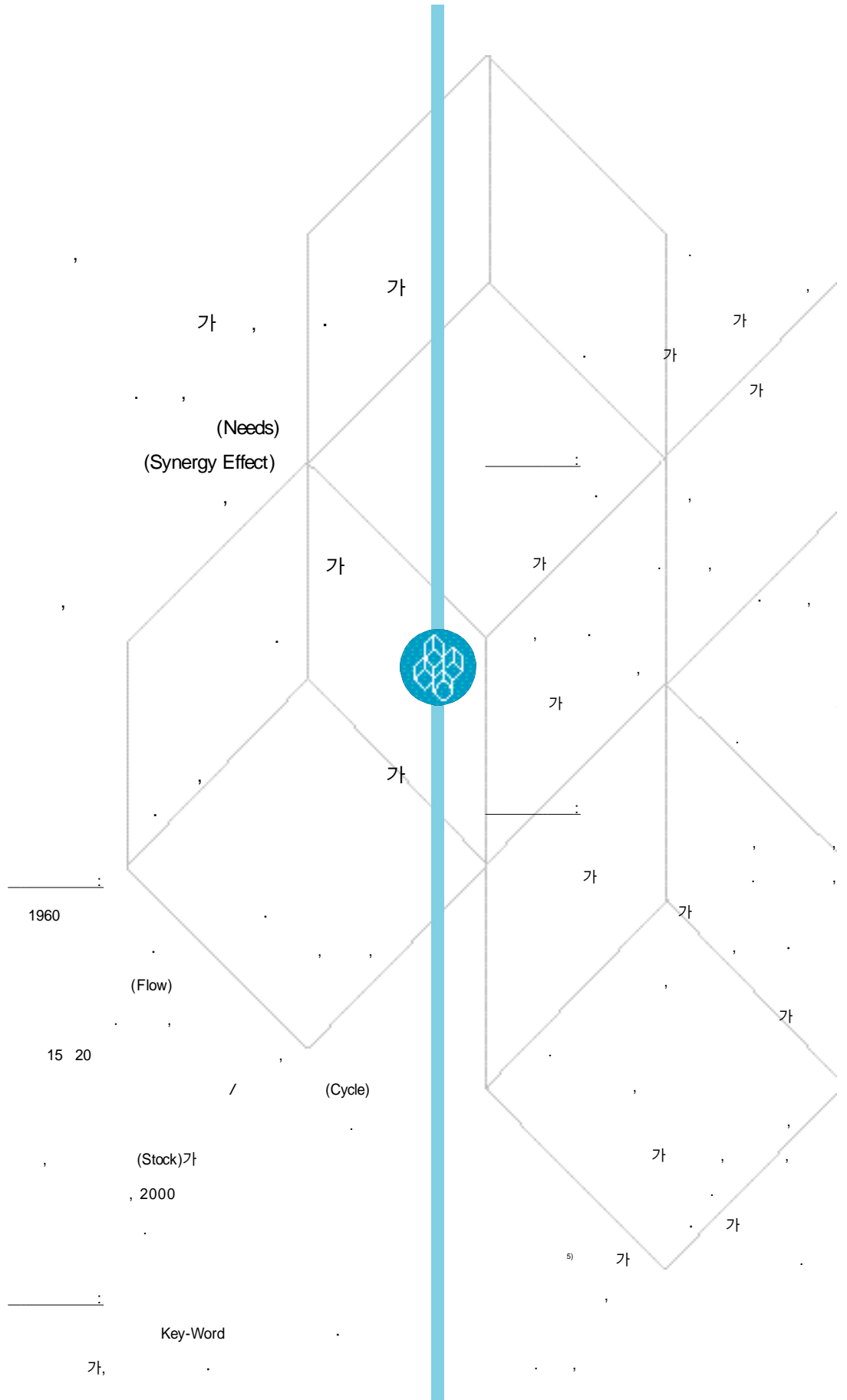

# R e n o v a t i o n

가

가

가

가

가

가

가

가

가

가

가

가

가

가

가

가

가

가

가

가

가

가

가

가

가

가

가

2003

가

17 1

2003

18.8%

IMF

가

가

T/F

, 2000  
2003

3 4

11 4

가

, 99

(Hidden Market)

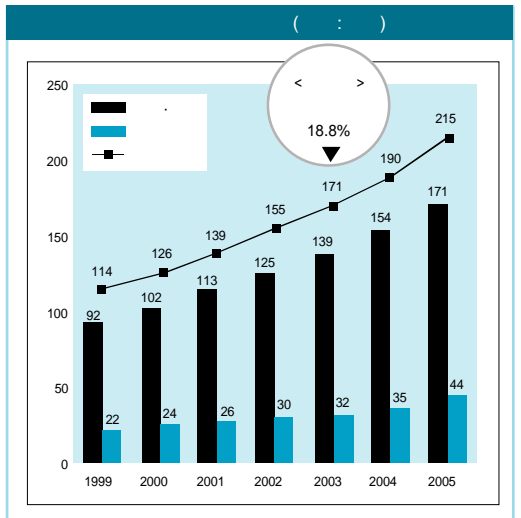



R e n o v a t i

# 건축물 리노베이션을 위한 건물성능평가

가 가

가

가

가

가

가

가 1960

(Environmental

Design Research Association, 1968)

가, 가, 가,

가, , , ,

가 , 가

가 가

1960

1970

GSA(General Service Administration)

. 70

가 ,

70

가 가

가

. 1980







research) 가 가 .<sup>3)</sup>  
 가  
 가  
 가  
 가 .( 3 )

(descriptive

가

가

가

1)

가

2)

가

< 4> 가	
	가
(behavioral)	, , ,
(cultural)	, , ,
(temporal)	, ,

< 5> 가	
	가
(functional)	, , ,
(technological)	, , ,
(economical)	, / , ,
(environmental)	, , , ,
(aesthetic)	



가 가

가 , 가

가

가

가

가가

가

가

1)

가

가,

가,

가

가가



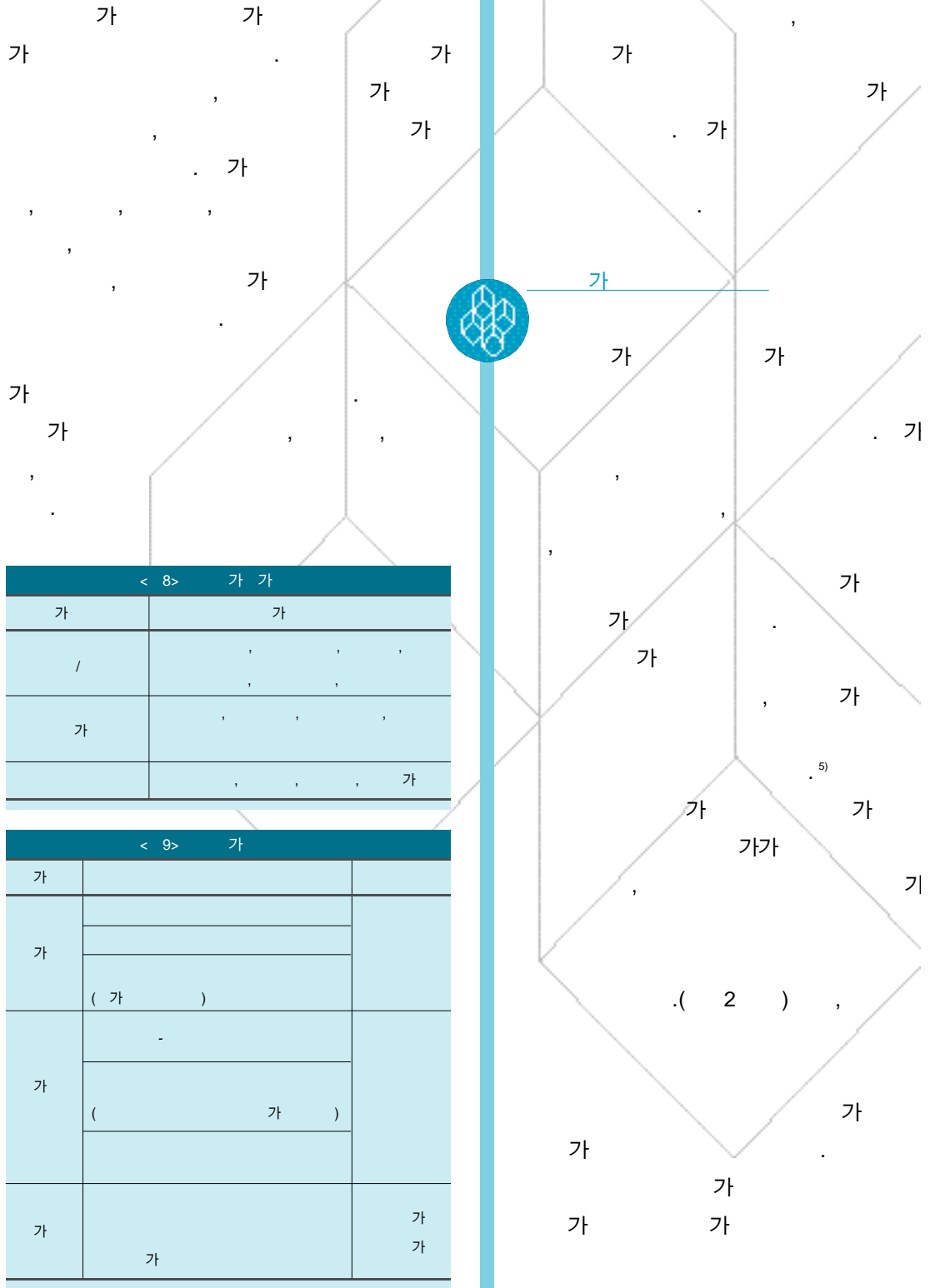

# R e n o v a t i o n

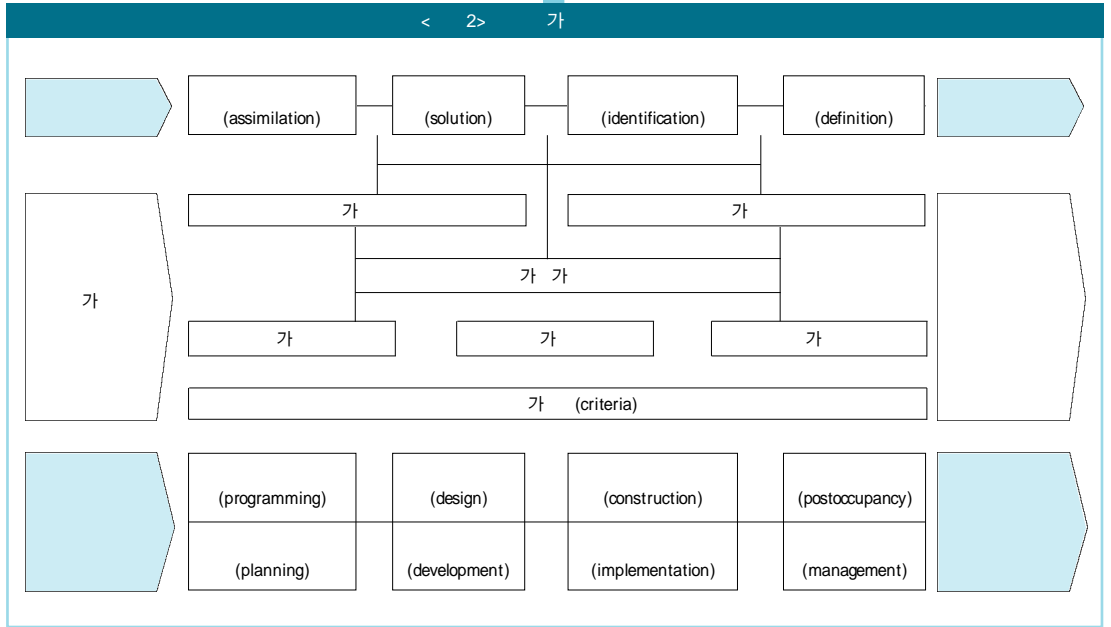

가

가

가

가

가

가

가

가

가

가





# R e n o v a t i o n

가

10% 가

2003

가 가 가

IMF

가

## < 1> LCC

(1%)	(16%)	(11%)	(21%)	(25%)

## < 2>

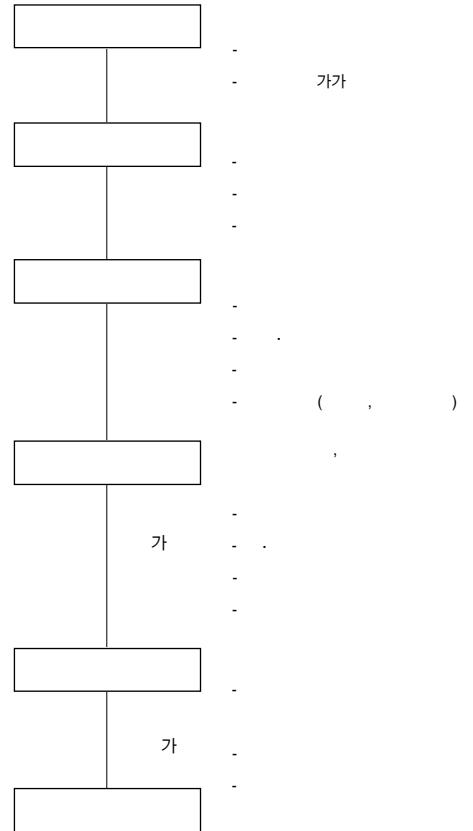

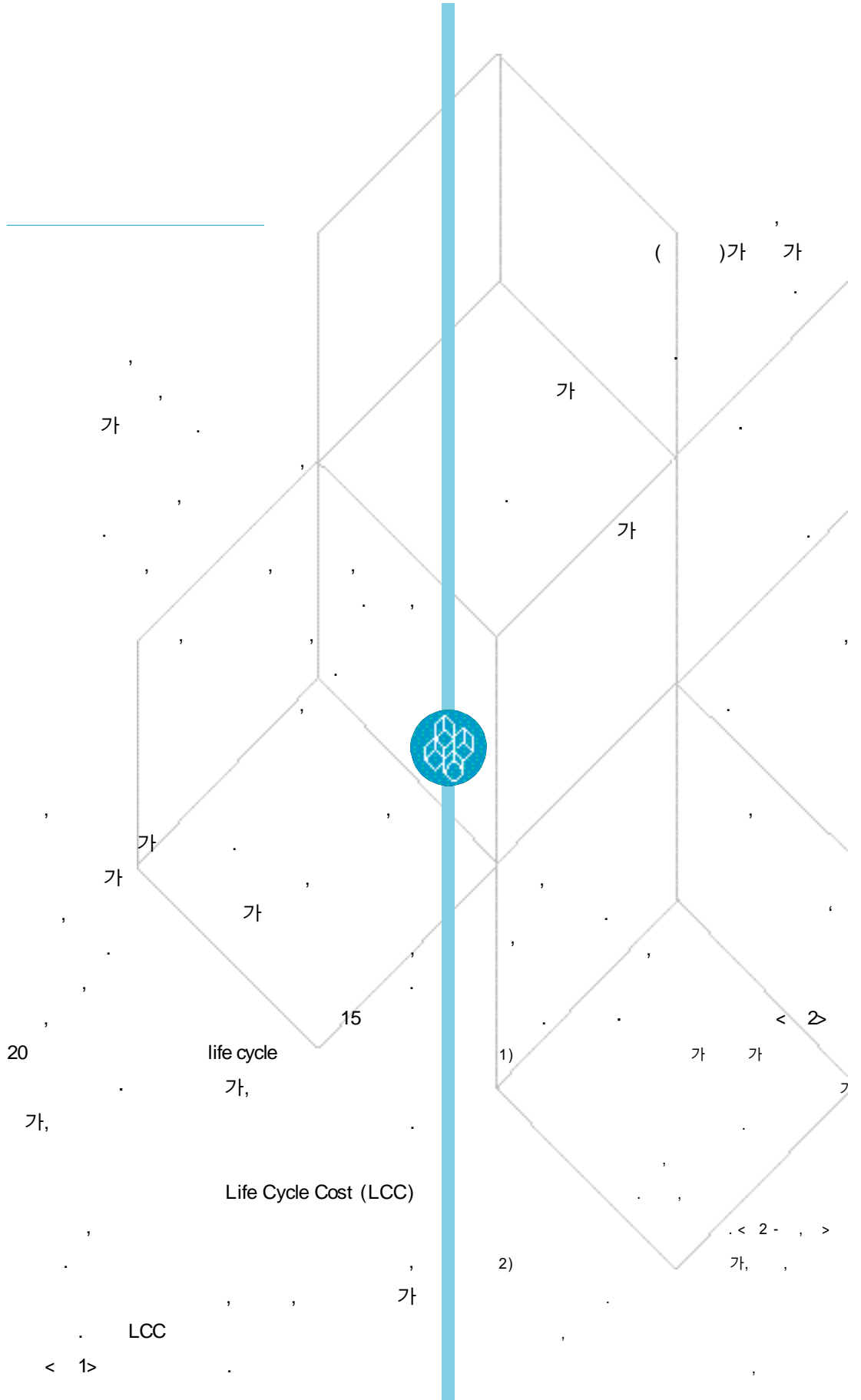

# R e n o v a t i o n

< 3 >

가 ( )

가

system

1 /

,

,

System

DUCT

2 /

가/

ITEM

/

3 /

가

,

( )

/

3)

work-scope



. < 2 - >

4) / 가

가

가

4)

가

adjusting &

balancing, 가

. < 2 - >

5)

1)

가

6)

(



),

2)

, 가 , , ,

70

가

가

가

3)



R e n o v a t i

# 주택 리노베이션 시장의 현황과 전망

가 가

,

가 가 .

가 가 ,

가 . 가

가

가 . 가

. 가

가

가 가 가

. 가

가 가

.

가 가

가 가,

가,

가

가

가 가

가 가 , 가 가

가 가 가

가 가 . 가

가 가

, 가 가

가

가

가

가

가

가

가,

가

가

가 가

가 . 가

가

가 가



가

가

가

가

가

가

가

가

가

가

가

가

가

가

가

가



가

가

가

가

가

가

가

“平成3年増改築, 改装

査”

< 1 >

가

가

가

(住宅のリ - フォム市場實態調査, 89年)

14.3%가

가

1

107 2

# R e n o v a t i

< 1 >		(91 )
増築	170,388	1 529
改築	14,091	1,516
改裝	445,366	6,687
	629,845	1 8,732

( : 住宅リフォーム産業の展開, (財)住宅産業情報サ - ビス, 平成6年9月)

5 7,900

가

가

가

( , 1994)

가

74.3%가

가

가

가

가 ( %)				
	18-26	27-39	40-55	
	91(64.5)	103(73.6)	106(86.2)	300(74.3)
	50(35.5)	37(26.4)	17(13.8)	104(25.7)
	141(100)	140(100)	123(100)	404(100)

가

가 ( %)	
	187(62.3)
2	14 (4.7)
2 -4	29 (9.7)
4 -6	38(12.7)
6 -8	16 (5.3)
8 -10	9 (3.0)
10	7 (2.3)
	300 (100)

(

)

가

?

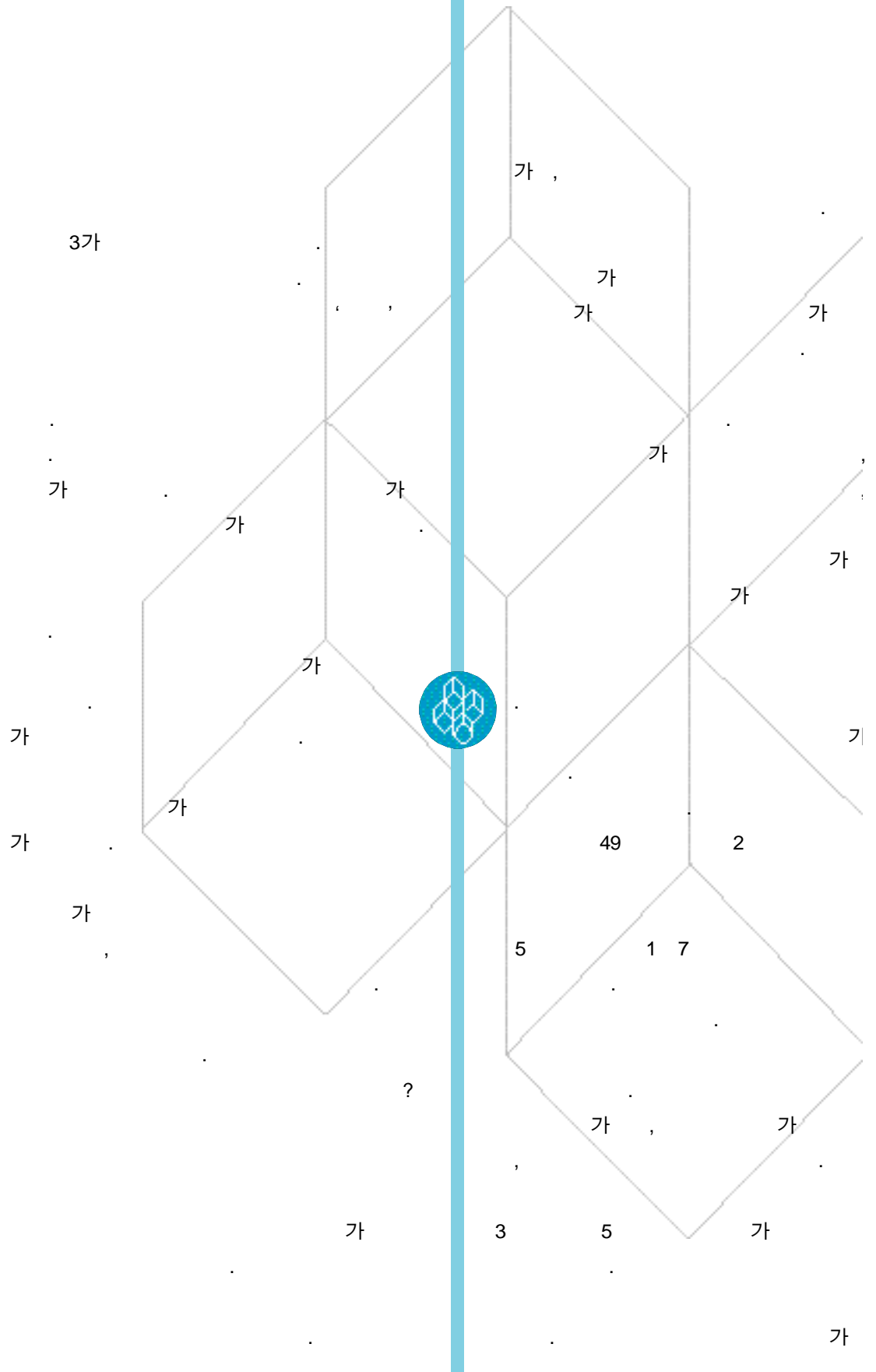

R e n o v a t i

가

2-3

가가

가

가

가

가

가

가

가

가

가

가

가

가

가

가

가

가

가

가

1

W

가

가



W

가

가





가

가

가

가

가

가

가

가

가

1) \_\_\_\_\_



가

2) \_\_\_\_\_

가

가

가

가

3) \_\_\_\_\_

가

가

가

가

4) \_\_\_\_\_

가

가

가



R e n o v a t i o n

# 건축물 리노베이션 공사수행 사례

## RAFFLES HOTEL RESTORATION & REDEVELOPMENT



(RAFFLES HOTEL : )



(RAFFLES HOTEL : )

\_\_\_\_\_ : Beach Road/Bras Basah Road, Singapore

\_\_\_\_\_ : Architects 61 ( 가 )

\_\_\_\_\_ : 3 4 (104 )

3 가6 ( )

\_\_\_\_\_ : 53,160m<sup>2</sup>

\_\_\_\_\_ : , , , RC

\_\_\_\_\_ : 1989. 9 1991.12 (27 )

가 가  
100 가 . 1987 3 가  
가

Conservation Zone New Development

1920

## S'PORE CHINA SQUARE PARCEL-E

\_\_\_\_\_ : Church Street/Telok Ayer Street/Pekin Street &  
China Street, Singapore

\_\_\_\_\_ : Architects 61 ( 가 )

\_\_\_\_\_ : 19 Units of Shophouses ( )

16 , 7 ( )

\_\_\_\_\_ : 62,613m<sup>2</sup>

\_\_\_\_\_ : R.C. + Prestressed Conc. Slab & Beam

Steel Structure Truss (Roof )

\_\_\_\_\_ : 1996. 9 1998. 8 (23 )

가



(CHINA SQUARE )



( )



가  
 1996 9 7  
 16 19  
 4 , 1 12m  
 21m  
 4  
 가 Raised Floor System  
 Ribre Ceiling Board  
 가 1m 가  
 180 Micro Pile  
 Sheet Pile Strut

\_\_\_\_\_  
 \_\_\_\_\_  
 \_\_\_\_\_ : 2 , 9 (518 )  
 \_\_\_\_\_ : 55,722m<sup>2</sup>  
 \_\_\_\_\_ : RC  
 \_\_\_\_\_ : 1995.11 1998. 9 (34 )  
 1995 11  
 200  
 518  
 1998 9 가  
 2 , 9 , 55,7  
 PC  
 가  
 35cm(250 ) , 1,400mm  
 가

# 가



Trubl Estimating

가

1997 11 ISO 14001

Engineering E/C < 1> 3 가

Consulting ( E/C)

E/C < 1> E/C

E/C

< 1> 가 (1997 ~ 1999)	
No	
1	
2	
3	가
4	가
5	가
6	가
7	가 가 가
8	가
9	/ , / 가
10	
11	
12	가
13	가

< 2> 가	
	1
	1, 2
	5
	3, 4
	7, 8
( , )	6

가

가

< 2> 가

가가

가

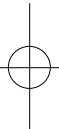

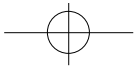

< 3>		가	
			11
			9
			10, 12
			1, 2, 7, 12
			6
		E/L	3, 4
	Duct		
			5
			8

< 3>

E/C

< 4>		
	/	
		5

< 4>

E/C

< 5>		: dB(A)		
		(05:00~08:00 18:00~22:00)	(08:00 ~18:00)	(22:00 ~05:00)
			50	55
		65	70	55
		60	65	55
		70	75	55

가 / ( ) :  
 2 4 1 2 +10dB,  
 +5dB

< 5>

9 1

9 1  
 (1994. 12. 23 )  
 가  
 65dB(A)  
 50m  
 가65dB(A)



Truck shooting

( ) L

가 ,

L-45, L-65 L-50,  
L-70

( )

	D-60	D-55	D-50	D-45	D-40
TV,					



< 6>

2) 2

< 1> 가

< 7> . 301 11

301

1

< 7>		5 가 ( : dB(A))	
		( )	( )
302 6	3 1	62.9	69.2
12:20~12:35 302 13	2	61.2	70.9
12:20~12:35 301 6	1 80ton 1	62.8	71.4
13:50~14:05 301 12	Back Hoe 1	64.7	72.5
13:50~14:05 301	1	59.5	61.5

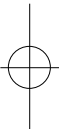



가

1)

가 가

, xx 가 . < 1>

< 6>	
	14 , 15 (302 ) 1 3 2
	13 (301 ) Back-Hoe 1 ( ) 1 ( )
	12 (301 ) 80 ton Back-Hoe 1

3)

가  
가

xx 가

2

( )

68.2~71.5dB(A)

70dB(A)

301





Tr aulb esthooting

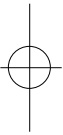

가

가80dB(A) 30% 가

가 1)

xx

65dB(A)

가 가

가 KS F 2810'

가

< 2>

65dB(A)

2) 가

( 가 ) L-65, L-50 가

( 1 ) 가 3 (L-60)

( ) 가 2 가

( : , 1 :

4) , 2 : , 3 :

< 2>

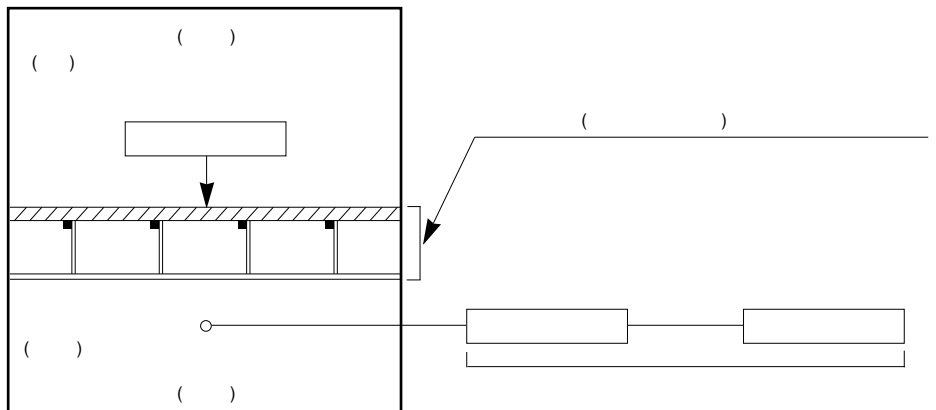



# NATM



Tr aubl eshooting

NATM

가

가

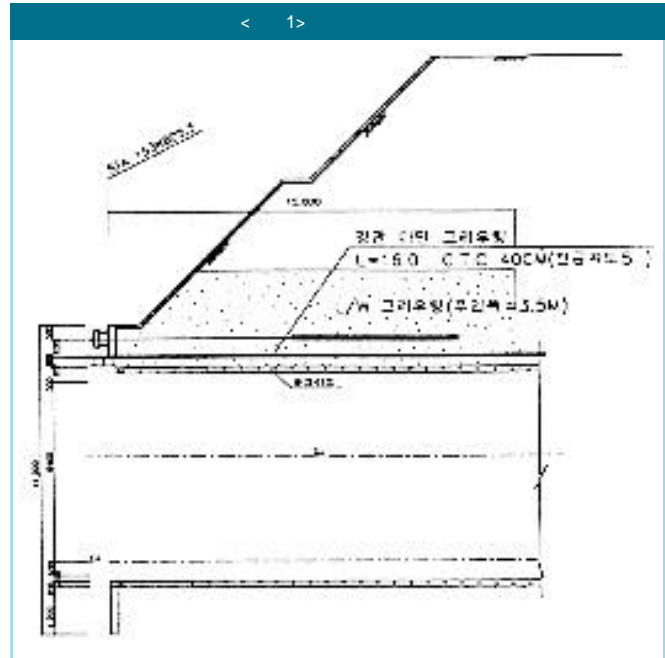

< 2 >

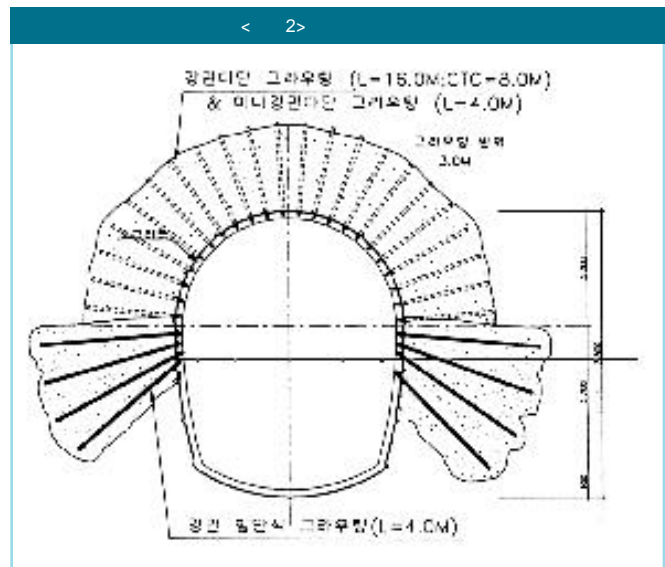

20m

가  
S.L

: 29.0m, : 17.4m

: Ring Cut, Mini Bench

(Bench = 8 ~ 12m)

: 0.6m

Shotcrete : T=20cm ( 1 : 5cm, 2 : 10cm, 3 : 5cm)

Wire Mesh : 1, 2 (5x100x100)

Rock Bolt : D25mm, L=3.0m, C.T.C 0.6m

= 3.5m

- 2.5m

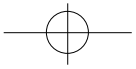

Feed Back

2

Slope

1)

1 ( 153k 810 )

: 3 11 ~ 3 17 , 6

: C = 24mm, Cmax = 42mm

: W = 7.6mm, Wmax = -10.1mm

Invert

Invert

2 ( 153k 820 )

: 4 23 ~ 4 30 , 7

: C = 20mm,

Cmax=20mm

: W = 17.32mm,

Wmax = -31.01mm

1 가

3 ( 153k 820 )

: 4 30 ~ 5 3 , 7

: C =

: W = 76mm,

Wmax = -107mm

8.4m

112

Back pr

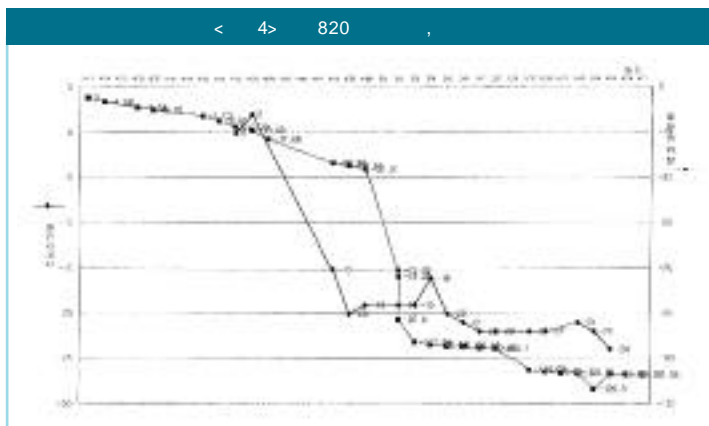
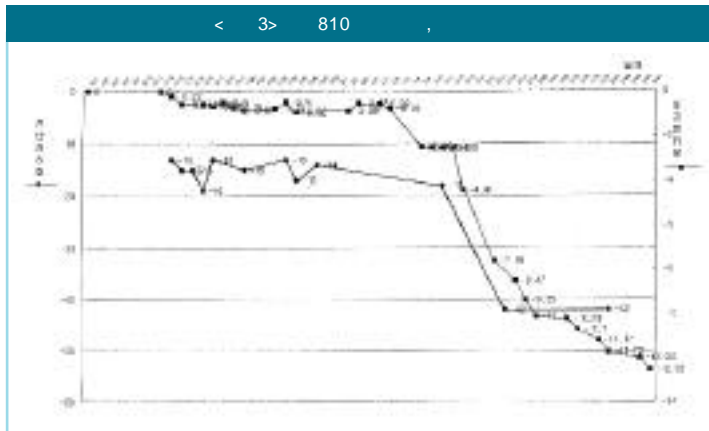



Trubleshooting

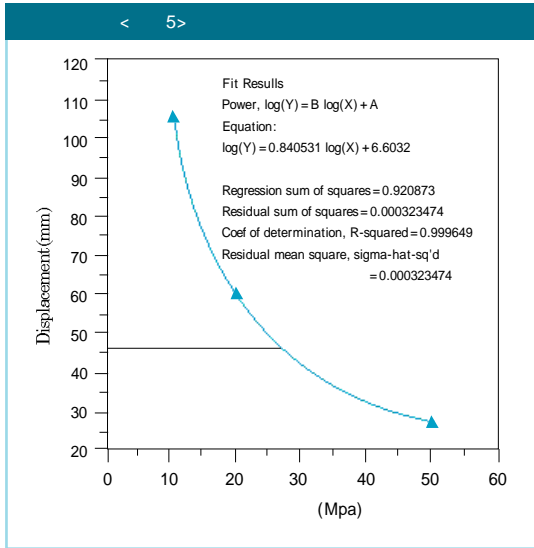

3 가 가  
 가 가

가 4 ( )  
 11mm, 35mm)  
 가 ( ) 10Mpa,  
 20Mpa, 50MPa 4

< 1 >

2) Feed Back

(1)

가 가

1.13%

(2)

83.24kg/cm<sup>3</sup>

3.00kg/

(Plastic Flow)

cm<sup>2</sup>

3.08ton

	( )	( )		Grouting
(m)	0.0 ~ GL-7.0	GL-7.0 ~ -22.0	GL-22	
(kg/m <sup>3</sup> )	1,700	1,800	2,100	1,900
(Pa)	13.57x10 <sup>6</sup>	27.14x10 <sup>6</sup>	135.7x10 <sup>6</sup>	54.28x10 <sup>6</sup>
	0.35	0.35	0.30	0.35
(degree)	20	30	35	32
(Pa)	10x10 <sup>3</sup>	20x10 <sup>3</sup>	100x10 <sup>3</sup>	80x10 <sup>3</sup>
(Pa)	5x10 <sup>3</sup>	10x10 <sup>3</sup>	50x10 <sup>3</sup>	40x10 <sup>3</sup>

가

(84kg/cm<sup>3</sup>) 99.1% 83.24 kg/

cm<sup>2</sup>

가

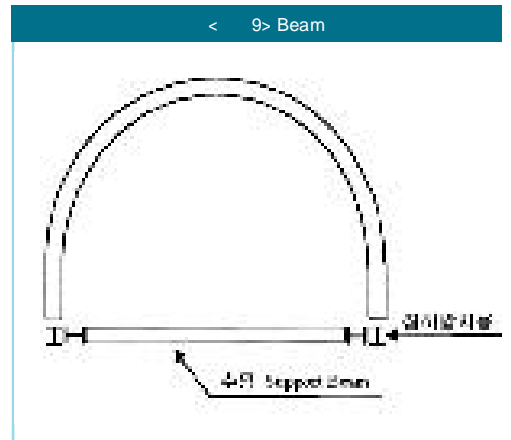
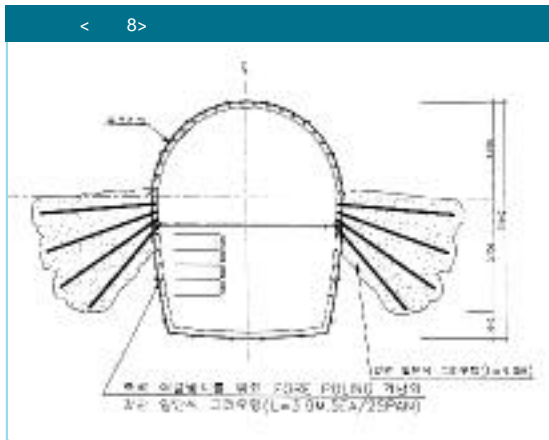
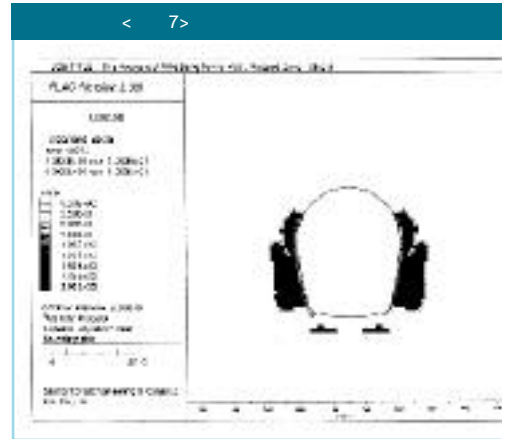
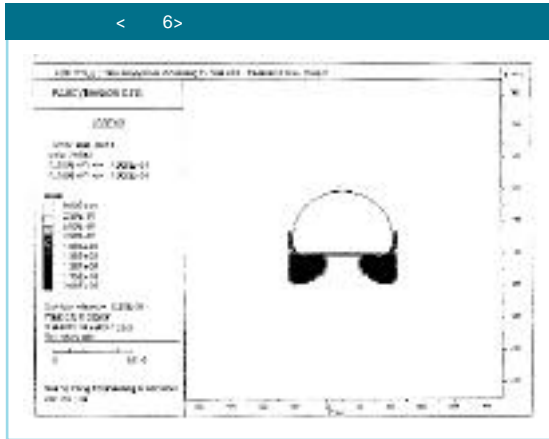
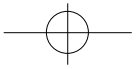

(3)

2.0m

(Step 4)

가

Fore Poling

< 8 >



Transecting

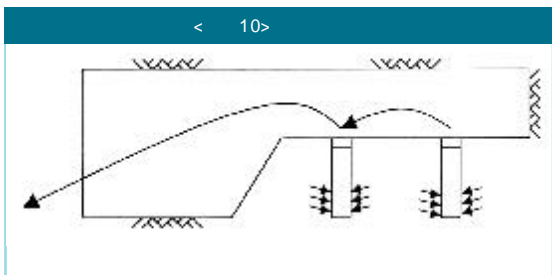

Bench(L=8~12m)

Shotcrete

Face

Bench

20m

8m

가

가

Beam

Support

Beam

가

Grouting

가

가

가

10m

가

(Lining Con c)

가

가

30.0m

Invert

Micro Pile

NATM

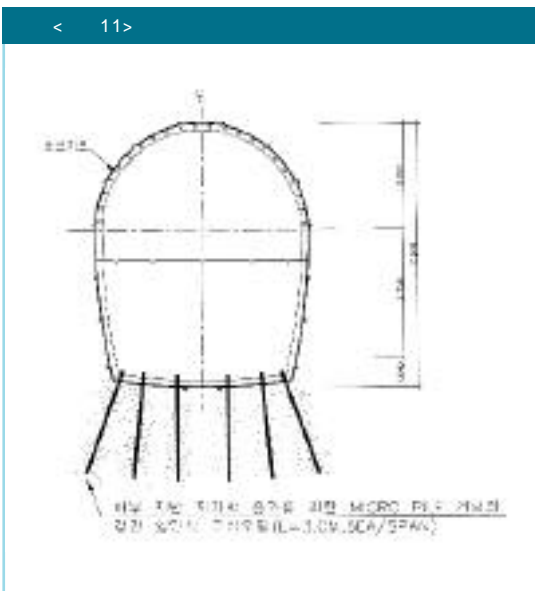

Mini Bench

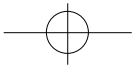

( )

가 가

가

가

1  
1 가

가

2) 가

, 1  
가

Con t  
System

1

)

(0.5H)

NATM

가

가

50m

가  
가

NATM

가

System

가

1) 가

가





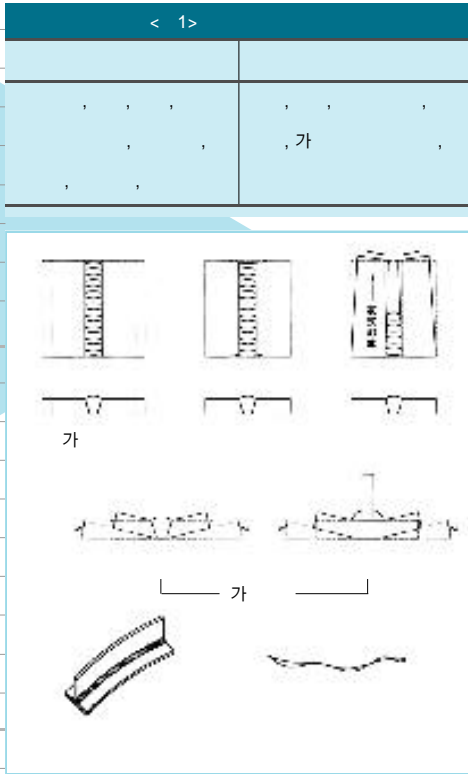
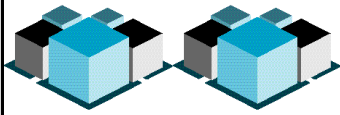

가

< 1 >

4)

가

1 (1 )

2 2

가

(Bearing type connection)

가

<

>

(Slip critical connection)

가

가



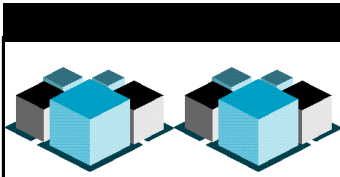

2)



가

Flange Web  
가



Bending

CAD/CAM

.가

3mm가

5) RIB, STIFFENER (FIT-UP)

Flange Web Rib,  
Stiffener, Diaphragm

가 .가

가  
40mm , 4mm

, 400mm

가  
가

가 SETTING

FCAW

3) Marking

Flange Web

CAD/CAM

Marking

가

1.6mm

Chamber

Web

Flange

가

Bending

가

. Bending 가

4)

BENDING

가

Bending

가

300mm

가

Plasma

50mm

Cutting Machine

Bending 가

Bending Crack

6) Box

Flange Web  
Setting 가

. Flang Web  
SAW



RIB STIFFENER

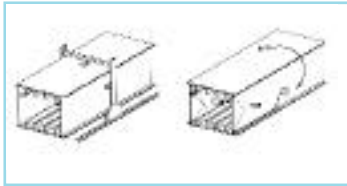
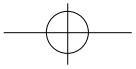

BOX

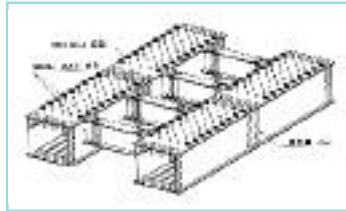

가



BOX



가

1  
가  
, Splice

9)  
가  
Box Segment

FCAW

가 . 가

가

Turning  
Box

10)

7) Cross Beam Stringer

가

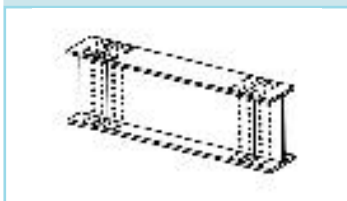

Cross Beam Stringer

Cross Beam  
Gusset Plate Stud

Bolt

가

(SAND BLAST) :

가

(WET BLAST) :

가

가

(SHOT BLAST) :

Cross Beam Stringer

가

(GRIT BLAST) :

8) 가

Elevation

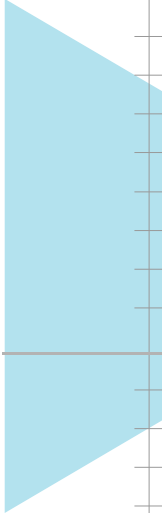
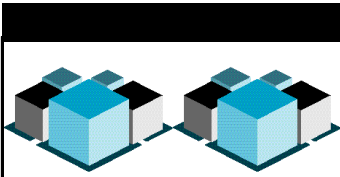

가  
(GRIT BLAST)

4

Box Segment

가가

12)



가

2

가 85%

가

(I.L.M),

가

가

가  
SOLE PLATE

가

(MASKING)

11)

가

가

,가

가

가

가

가



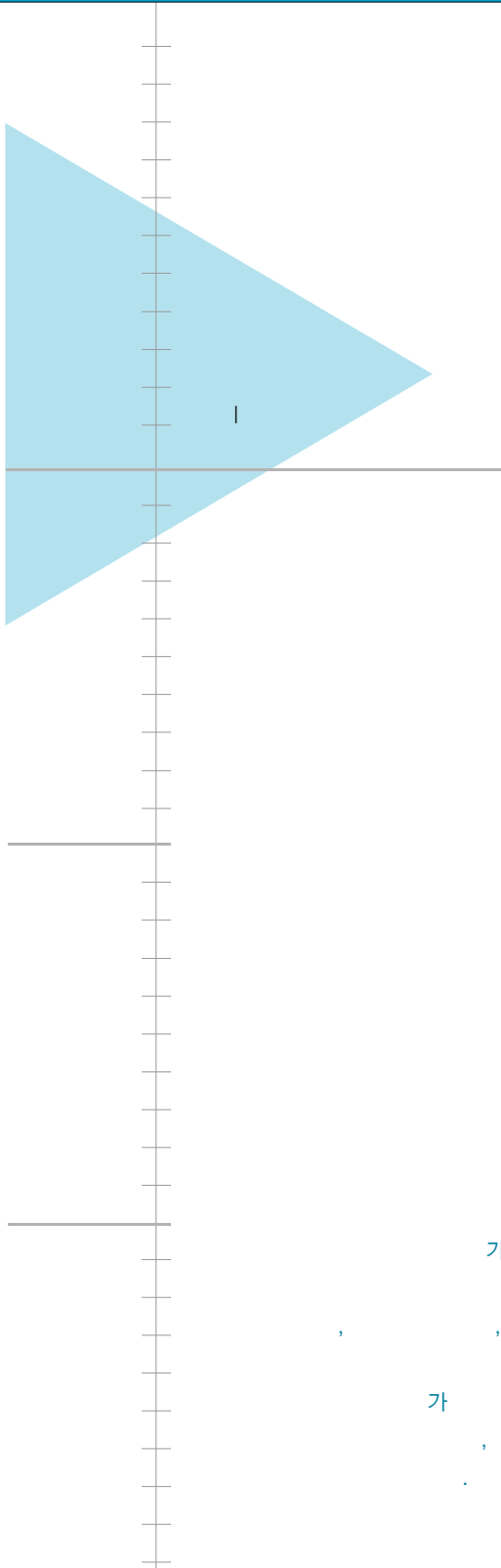
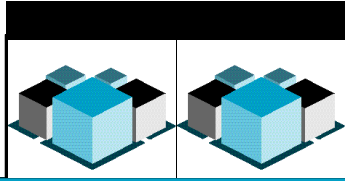
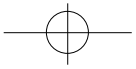

가  
1983 6

Earth Shel

Building

Infra-Structure

가



가

Infra-Structure

가

가  
가

가

가가

가

가

( )

가

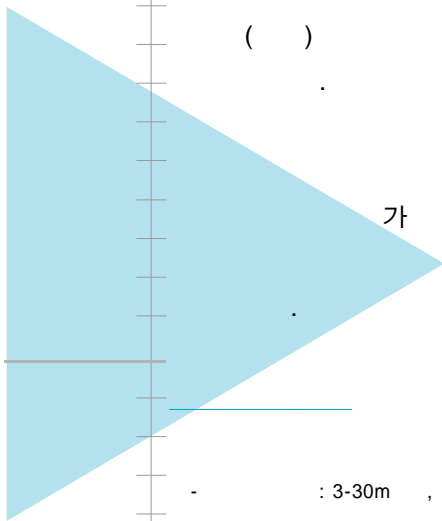
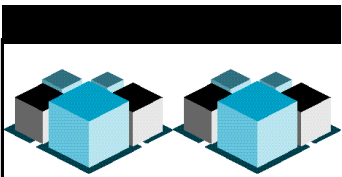

( )

가

- : 3-30m , 가

- : 30-300m ,

- : 300-3000m ,

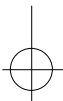

가 , , ,

가

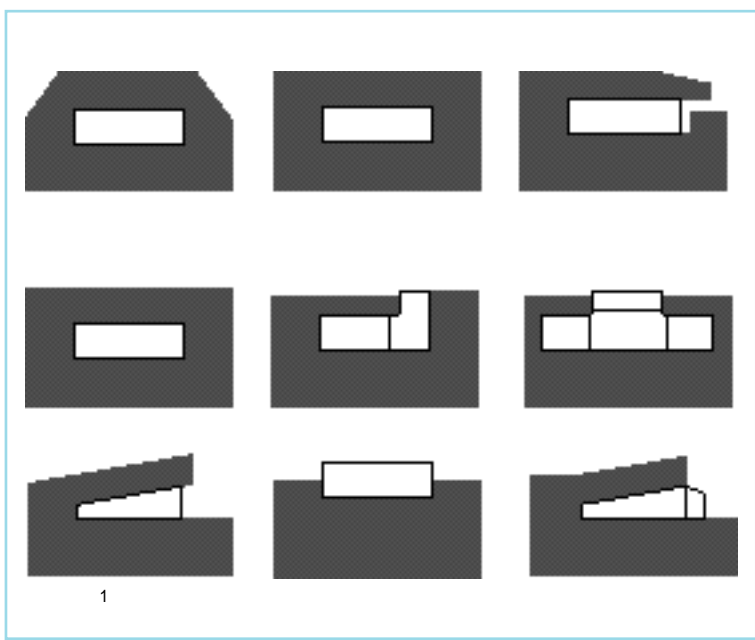

1

- Live Load

가

( )

- Dewatering (

Pumping : )

300m

가

(

가

- Test Wall

가

(Dron Panel)

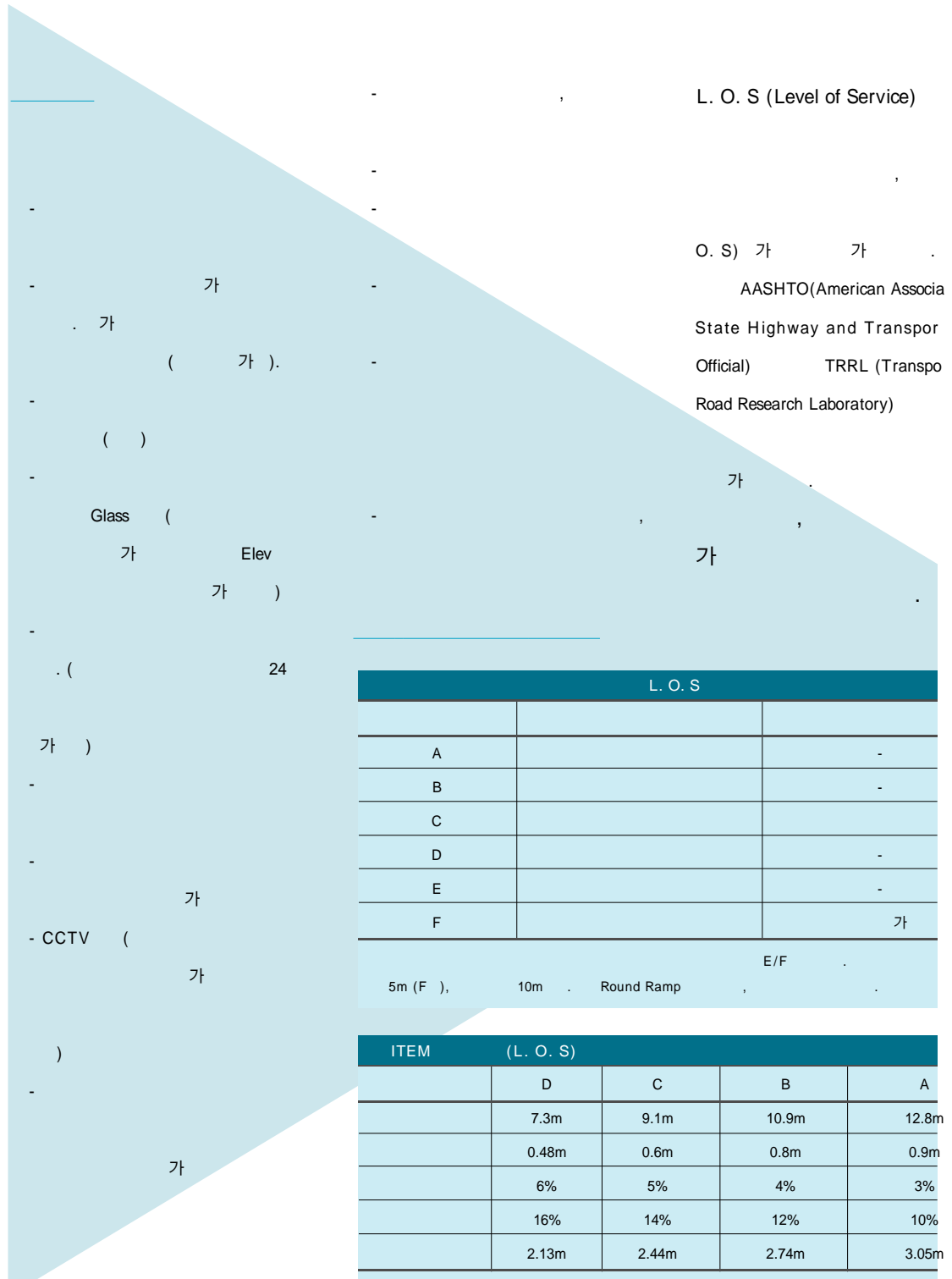
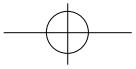

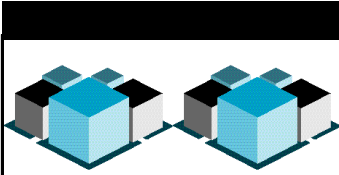

	NPA	IES
	40	50
	20	-
	20	10 / 15 / 20
	6	5
	2	-
	-	10
	2	3.6 / 2.4 / 0.8

NPA : National Parking Association (England)

IES : Illuminating Engineering Society Sub Committee on Off-Roadway Facilities

가

50%,

100%,

CCTV

85cm

70lux

100%

( 6 )

가

DC

100lux,

50lux,

300 ~ 200lux

가

가

300 ~ 700lux :

150 ~ 300lux :

가

70 ~ 150lux :

30 ~ 70lux :

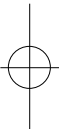

가

가

가



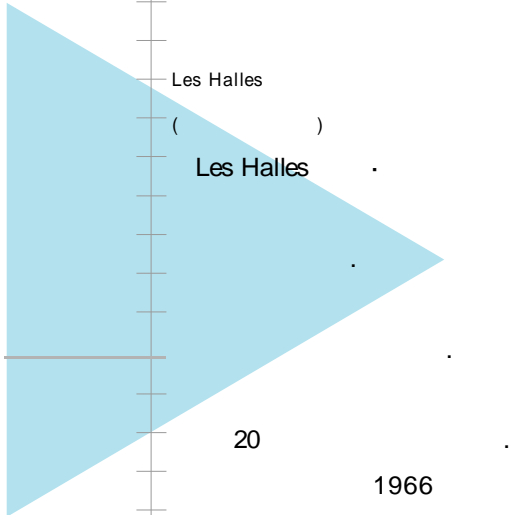
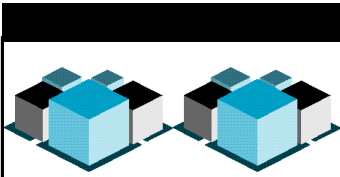

B5	
B4	
B3	
B2	METRO
B1	FORUM

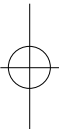

Paving

Open Space

Decking

( ) Sunken  
 “ 가 ”  
 .  
 -  
 -  
 - 2 (10-15 )  
 - (4230 )  
 CCTV  
 -  
 - ( )  
 -  
 - 6  
 -  
 가  
 ,  
 가  
 가  
 가

Eaton Center (Toronto)

-	( )
- 1000	가
-	
-	Mall 1 3
-	
-	, 1970
-	Path
-	Gas

/ Bus

Atrium ( )

가

Open

가

가 All Air

- Air Curtain

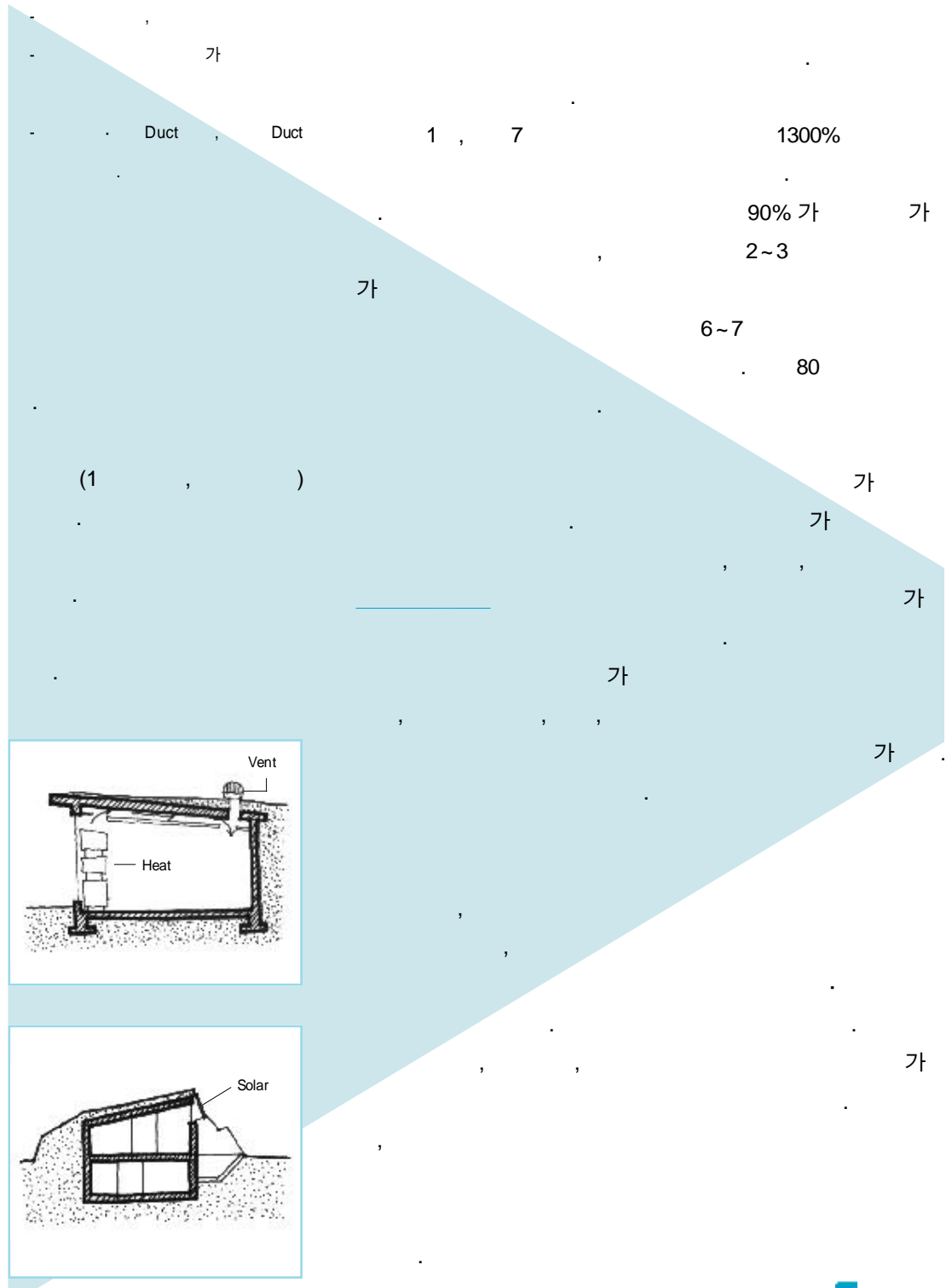
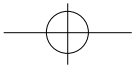

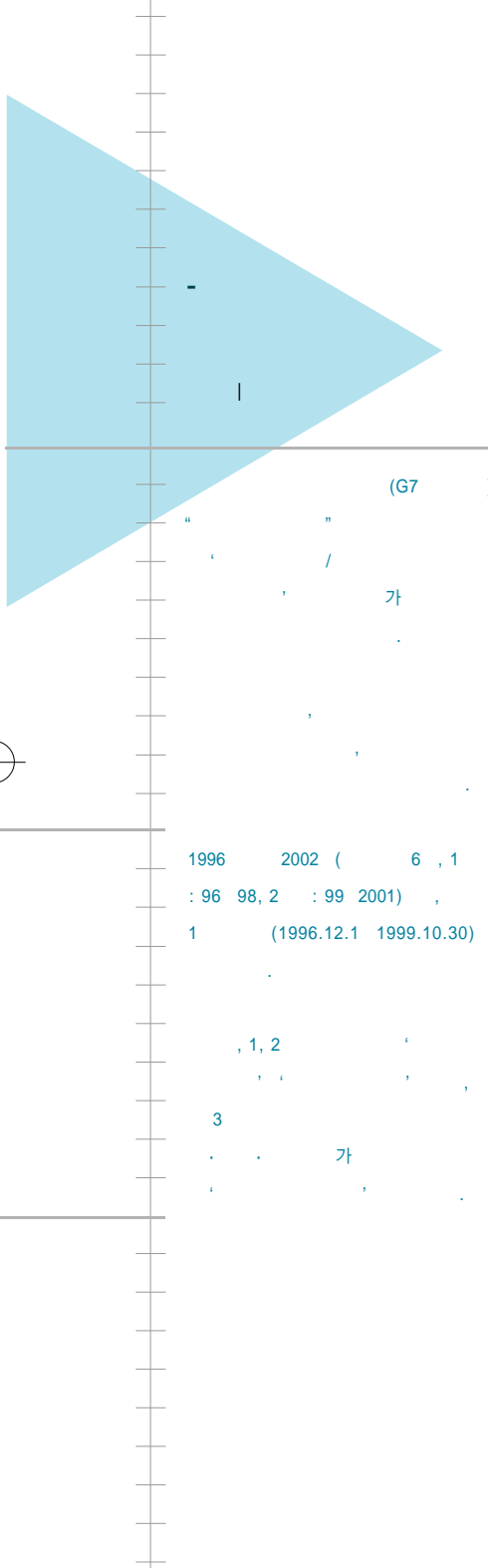
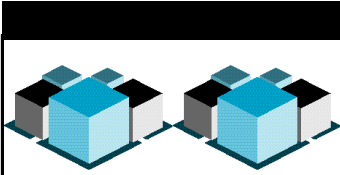

가

가

가 , ( , , )

(G7 )

가

가

,가

가

가

가

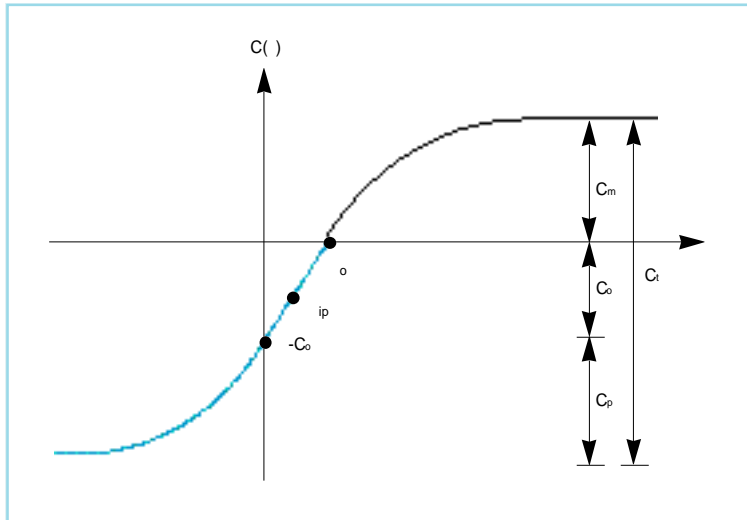
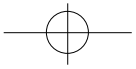

Panet 1979

$$C(x) = C ( 1 - \exp(-bx) )$$

$C$ ,  $b$ ,  $x$

< 1>

가

$$C(x) = C ( \exp(-bx_0) - \exp(-bx) )$$

Otusuka(1981) Ke

Voigit

$$C(x) = a(1-\exp(-bx)) + c(1-\exp(-bx))$$

$a, b, c, d$

$x, t$

(C<sub>t</sub>)

(C<sub>m</sub>)

< 1>

x

C(x)

가

(C<sub>0</sub>),

(C<sub>p</sub>)

가 (Panet, 198

$$\frac{C(x)}{C} = 1 - \left( \frac{1}{1 + \frac{1}{r} \frac{1}{a}} \right)$$

$r, a$

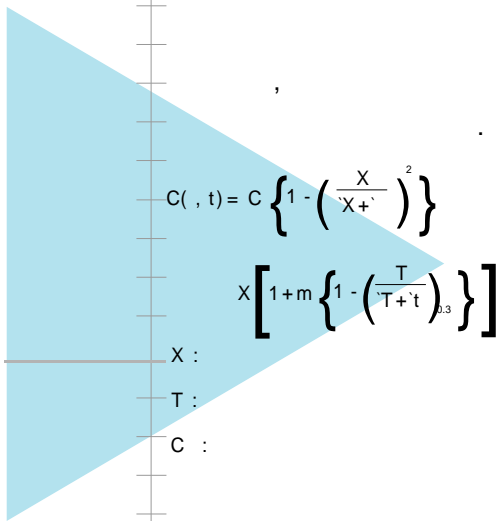
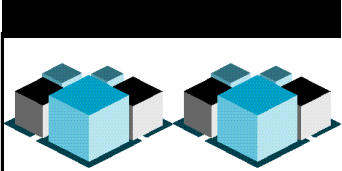

$$C(t) = C \left\{ 1 - \left( \frac{X}{X+t} \right)^2 \right\}$$

$$X \left[ 1+m \left\{ 1 - \left( \frac{T}{T+t} \right)^{0.3} \right\} \right]$$

X :

T :

C :

C (1+m) :

d : 1

k :

x<sub>0</sub> : (

)

x :

(

)

\_\_\_\_\_

가 ,

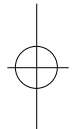

< 1 >

( , )

가

( .

· , )

S

가

S

가

. S

가

$$C(t) = \frac{a}{1+e^{b(t-d)}} + d \quad < 1 >$$

$$C_t = C_m + C_o + C_p$$

$$K = C_p / C_o$$

a : (=C)

b :

< 1 >	
	, , , ,
	, RMR/Q( )
	( , , )
	/
	/
	, ,
	/
	(a d)



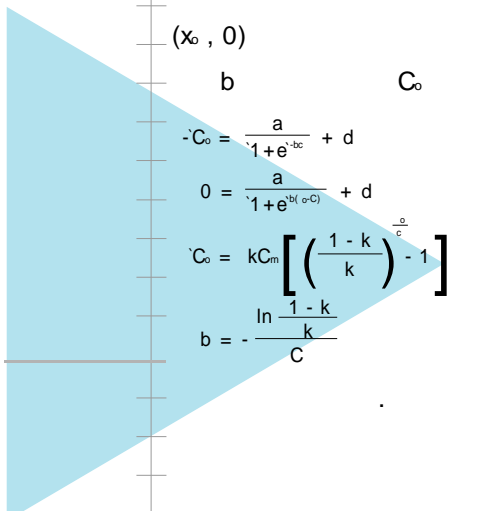
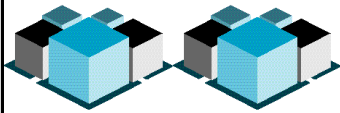

(i)  $c (= ip)$   
 $k (0 < k < 1)$  가  
 $C_0$  a, b, d  
 S  
 $(C_{ei})$   
 (ii)  $(C_{mi})$   $(C_{ei})$   
 (AVR, Average Relative

$$AVR = \frac{1}{N} \sum_{i=1}^N \left| \frac{C_{mi} - C_{ei}}{C_{mi}} \right|$$

Error)

(iii) (i) (ii)  
 c, k

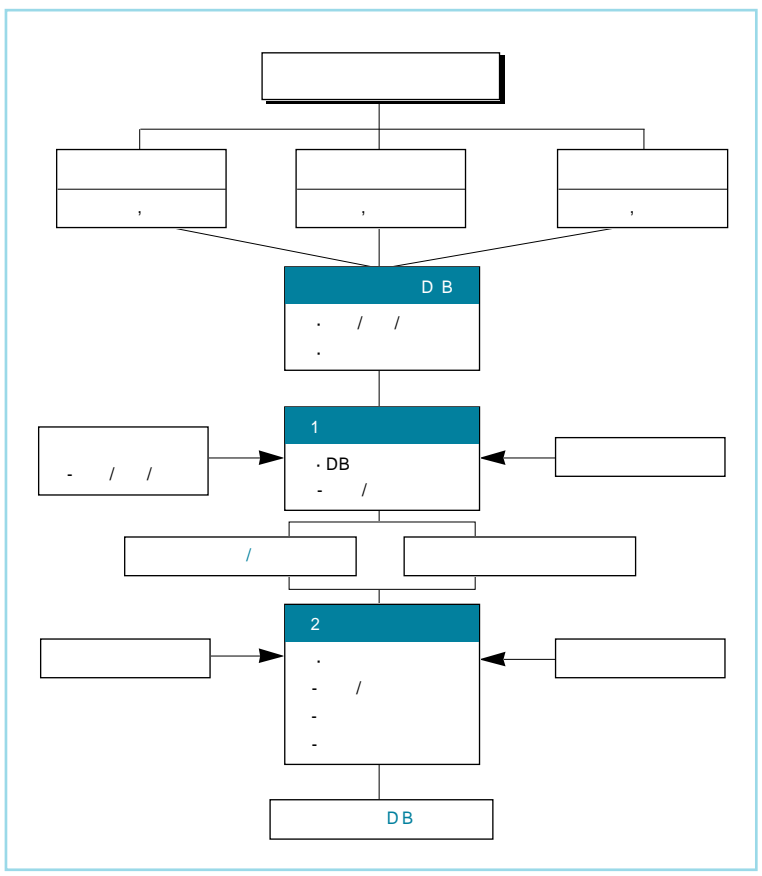

< 3 >

( )  
 ,  
 가 , , 가 ,  
 가



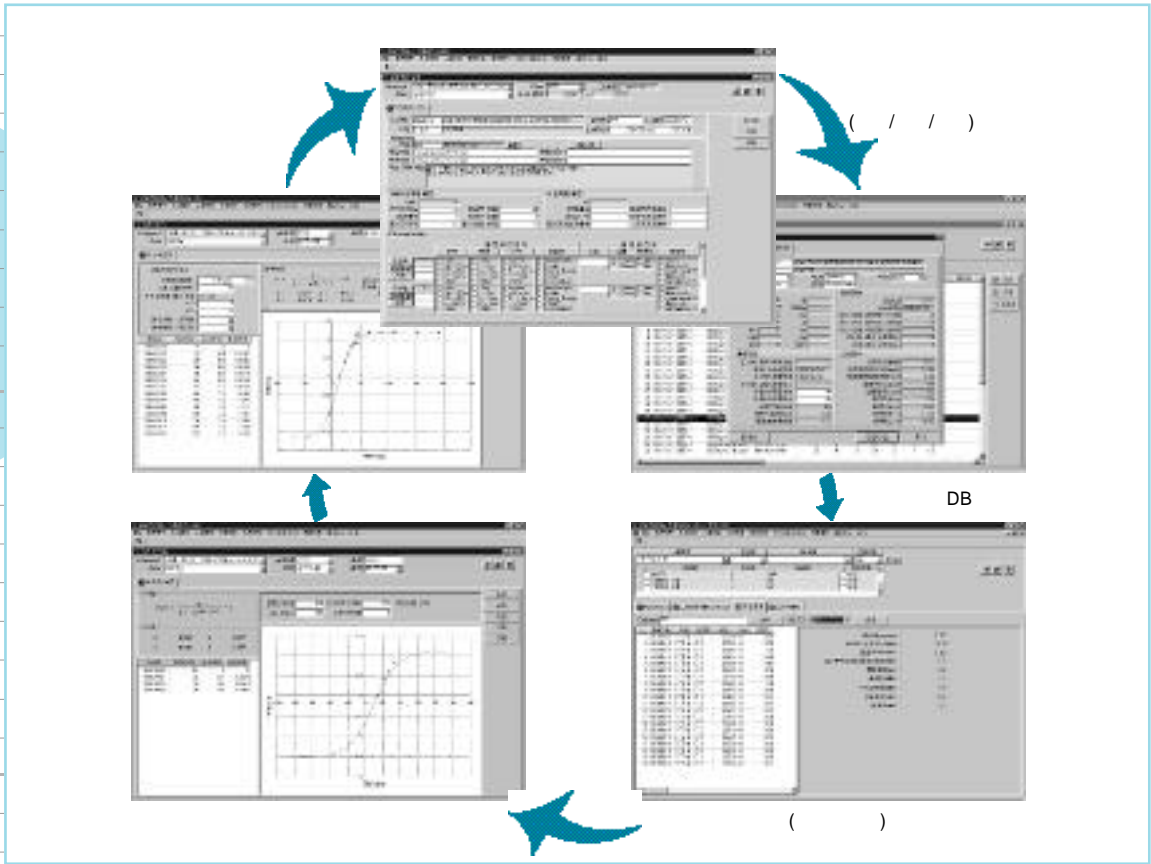
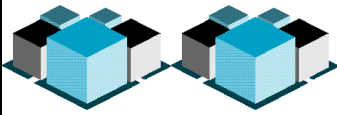

< 4>

, )

< 5>

. ' 2

, ' 1

1

/ ,

1-00 PD-1( )

8-00

, / / , ,

( , 1996)

k=0.3 가 . < 5>

DB

가

가





( )



가

(芳香)

1)

(1) \_\_\_\_\_ :

(2) \_\_\_\_\_ :

2)

(芳香)

- \_\_\_\_\_ (Aldehyde) :

가

- \_\_\_\_\_ (Terpence) :

- \_\_\_\_\_ (Diene) :

( )

- \_\_\_\_\_ (Alcohol) : ( ) 가

- \_\_\_\_\_ (Ether) :

- \_\_\_\_\_ (Oxide) :

가

가

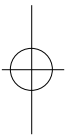



- (Acid) : , 가 .

- (Ester) : , , .

- (Phenol) : .

- (Ketone) : , , 가 .

, , 가 , , 가 .

1)

, 가 (workaholic) . 가 가 가

3)

, 가 가 , 가 .

가

2)

4)

가



가

가

( )가

( 99-16697 )

가

가

가

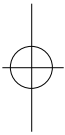

C 24mg  
C 10mg

가

E,

B · C ·

B

가

C가

1)

(1)

POWER ON(1 )

ON/OFF



Timer (2 )

10, 30, 60



(3 )



(4 )

(2)

(3)



가



2)

Case, Controller

(1) Case :

(2) :

(3) :

Timer

(4) :

(5) Controller :

가

-

-

-

-  
-  
-  
가  
가

1. The Essential Oils, Ernest Guenther Ph.D; D. Van Nostran Ltd.
2. The Art of Aromatherapy; Robert Tisserand; The C.W. Dar Ltd.
3. The Essential Oil Safety Manual, Robert Tisserand; The Association of Tisserand Aromatherapists.
4. Aromatherapy for Everyone, Robert Tisserand; Penguin.
5. The Aromatherapy Handbook, Daniele Ryman; The C.W. D Co Ltd.
6. Lecture Notes on Essential Oils, David Williams MR Pharm Eve Taylor (London) Ltd.
7. Aromatherapy: The Use of Plant Essences in Healing, Rayr Lautie D.Sc & Andre Passebecq Md DPs; Thorsons Publ Group.
8. The Best of Health: Thanks of Essentials Oils, Paul Duraffc La Vie Claire.
9. Aromatherapu, Judith Jackson; Dorling Kindersley.
10. Aromatherapy of Woman, Maggie Tisserand; Thorsons Publishing Group.



...

- .

|

—

가 , , ,

가

가

, 가

54%

( ) , ( )

, ( )

가

가

( )

( )

가

( ) 50%, ( )

30%, 20%

가

1996 6

가

1997

9

( )

1998 5

( )

가

, 1998 7

1999 5

(( )

25%가

( ) )

, ,

,

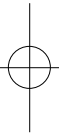

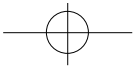

가  
( ) ,

“ ” ,

4,189.02m<sup>2</sup> 가 100 ( )

3  
450 ( : 55 / × 2 ) 100 ( )

20 ( ) “ ” ,

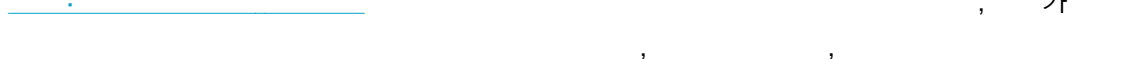

1977 ( 6 )  
)가 6

가 ( 78 )

	[ ]
가	78 - 92
가	78 - 92
1) ( )	( )



가

. ( 85 7 )

가

4

가

가

가

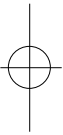

\_\_\_\_\_

-

-

13

-

가

\_\_\_\_\_

-

-

13

- 가

-

가

가

( )

2

. ( )

RC

(

가

SPAN

98 2

)

BEAM

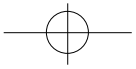

INPUT DATA

. 2  
가 가  
가

가

가

2)

( 40-60 )

가

(가)

		1,575	3,290	1,7

		0	235	23

	m <sup>3</sup>	9,338	20,817	11,4
		1,513	2,862	1,3

	m <sup>3</sup>	0	15,000	15,0

	m <sup>3</sup>	0	821	8
	m <sup>3</sup>	0	1,222	1,2

( ) 가

가

16%

가

가

			/ 가	
		1,715	926	1,588
		235	1,126	264
	m <sup>3</sup>	11,479	44	505
가		1,349	577	778
	m <sup>3</sup>	15,000	3	45
	m <sup>3</sup>	1,222	61	74
				3,256



( )

가  
가

가  
.( 45,107-2328)  
가

.

가

가

가 ,

( 64 ),

( 65 ),

가

( 66 ) 가

. 가

가가

가

.( 64 2 )

가

가

가가

)							
		가		가			
	10	5	50	4.5	45	-5	
	5	6	30	6	330	-	
	4	5	20	7	28	8	
	0	-	0	3	-	-	
	0	-	0	3	-	-	
			100		103	3	

= ( / )X100 = (3 / 100) X 100 = 3%

.( 91 2 )

가:

가

가

가:

가

가

가

가:

가

- 98.2.2

가

가

가

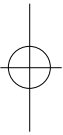

- ( / )X100 = (30/100)X100 = 30%

가



8



가

가 ,  
가

3

가

가

가 ,  
가

3

. IMF



가 ,

가

가 ,

가







가

3 가



6-6

4km

6-6

4

70%

6

가

가

가

30

가

가

가

가





/

/

가

가



가 가

가

가

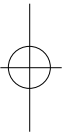
|



	( )		
	10-1999-0039666		
	1999 9 15		
	: Zero Sound		
	: 99-40453		
	: Good Morning		
	: 99-40454		

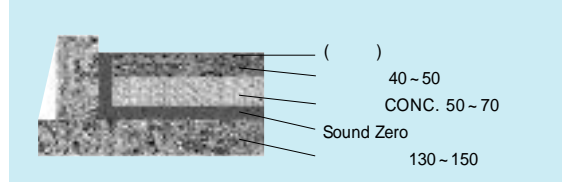
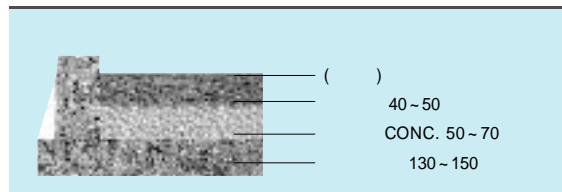
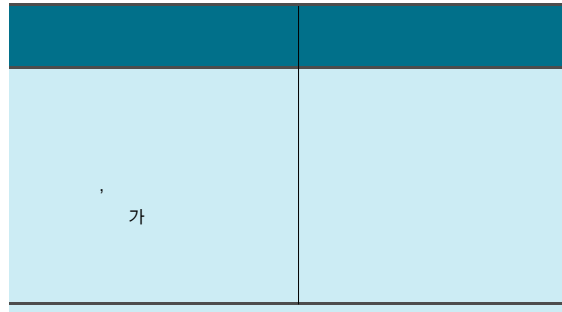

-  
-  
-

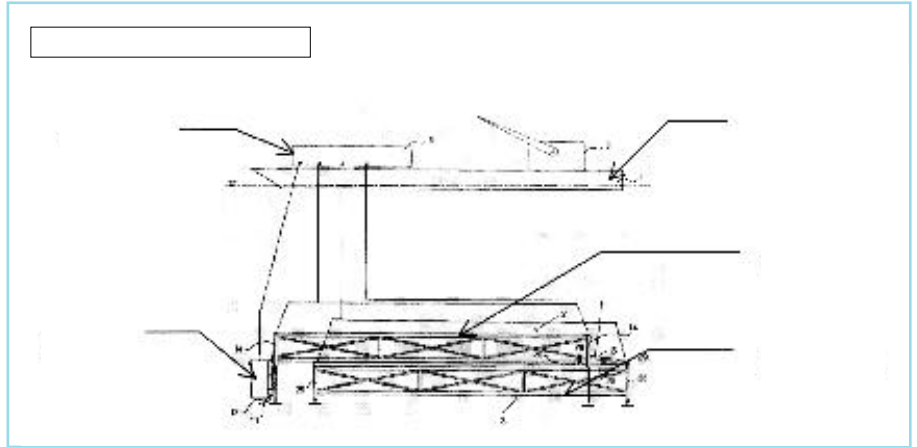
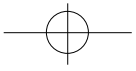

, . 가

가

		(RECSUF)	
	( )		TF
	10-1999-0043658		
	1999 10 9		

-

-

-

-

-

가

/

15m

가

-

-

-

-

( )

가



Q

?

A

1  
1~2  
5~10  
1/3~1/2  
( )  
1M

Q

A

가 ?

Close Joint    Open Joint

3가

가

가

Close joint (

)

Open Joint

< 1> 1M (BPM)		PHC	PC
BPM ( )	500	200	120
(mm)	2	5	8

6가

Open Joint

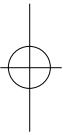

가

가

< 2>			
		PHC	PC
	3000	3000	2000
10M	1500	1500	800

가

가

가,

가

1970

1950

Close Joint

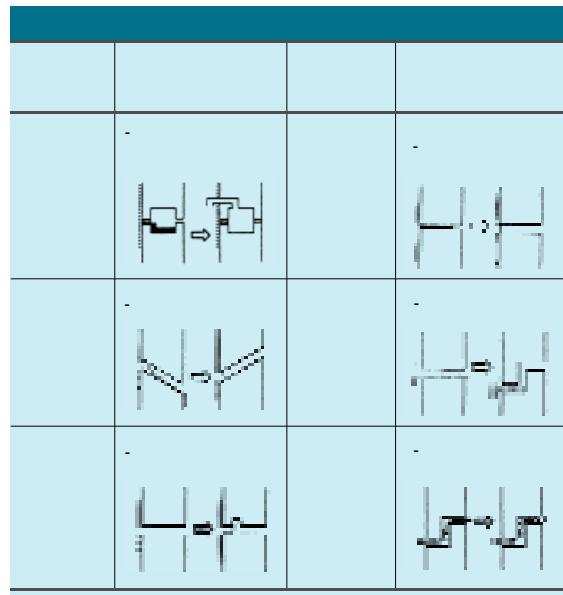

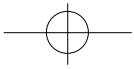

Q

A

?

(Magnitude) (Intensity)

“ ” “ ”  
10( 11) “ ”  
7.6 10

가 가  
(Richter magnitude scale) 1935 가  
100km 가  
가

1 12 12 (Modified  
Mericali Intensity; MMI) , 0 7

8 JMA(Japan Meteorological Agency)  
MMI

$$\text{Mag} = \frac{1}{2} \text{MMI} + 1.75$$

$$\text{Mag} = \frac{2}{3} \text{MMI} + 1$$

Mag , MMI

12	
	가
	가 가 가
	가
	가 ,
	가 가
	가

(USGS) 1.0  
6.0  
139 , 8.0  
, 100 9.0  
3 . 1  
' 8 - 17 ' 7.4  
? 19  
, 33  
3.5  
3.0 14